

## TABLE OF CONTENTS

<b>DEPARTMENT E - HEALTHY LIFESTYLES .....</b>	<b>E1</b>
<b>DEPARTMENT E - FOODS, NUTRITION, PRESERVATION ...</b>	<b>E1</b>
DIVISION 350 - GENERAL.....	<b>E3</b>
DIVISION 400 - CAKE DECORATING.....	<b>E4</b>
DIVISION 401 - SIX EASY BITES .....	<b>E7</b>
DIVISION 300 - YOUTH IN MOTION .....	<b>E7</b>
DIVISION 402 - FAST FOODS.....	<b>E8</b>
DIVISION 410 - TASTY TIDBITS .....	<b>E9</b>
DIVISION 411 - YOU'RE THE CHEF.....	<b>E10</b>
DIVISION 413 - FOODWORKS .....	<b>E11</b>
DIVISION 407 - FOOD PRESERVATION .....	<b>E13</b>
<b>DEPARTMENT E - SAFETY .....</b>	<b>E19</b>
DIVISION 440 - CITIZEN SAFETY CLASSES.....	<b>E19</b>
DIVISION 450 - FIRE SAFETY .....	<b>E21</b>
DIVISION 460 - WEATHER SAFETY.....	<b>E21</b>
<b>DEPARTMENT E - HEALTHY LIFESTYLES .....</b>	<b>E22</b>
DIVISION 200 - HEALTH CLASSES .....	<b>E22</b>

## DEPARTMENT E - HEALTHY LIFESTYLES

### DRESS CODE -

**Please follow the dress code for your county as noted in the "General Rules and Regulations" section of this fair book.**

### ENTRIES PER EXHIBITOR -

**County Entries** - No limit to number of exhibit per class unless otherwise noted in class description.

**State Fair** - State Fair has limits to entries per exhibitor and could be different in each division (please refer to the Nebraska State Fair Book).

**IMPORTANT** – There is **NOT** a **County Only Section** in the Fair book. There will either be a **CF** or **SF** in front of every **Class Number**.

- **CF**: means that exhibit is **ONLY** eligible to be exhibited at the **County Fair**.
- **SF**: means that exhibit if **CHOSEN** at County Fair is eligible to advance to **State Fair**.

## DEPARTMENT E – FOODS, NUTRITION, AND FOOD PRESERVATION

### GENERAL INFORMATION

4-H members may exhibit only in the projects in which they are enrolled. Baked products entered in county fair cannot be entered at State Fair. Products should be baked the day before entry day. All static exhibits must have received a purple ribbon at the county fair to advance to the State Fair. Premier 4-H Science Award is available in this area. Please see Department H for more details.

**Labels - For Food Products** - Each exhibit **must** include the recipe. Recipe may be handwritten, photocopied or typed. Place the food on the **appropriate size plate**. Put exhibit in a **self-sealing bag**. **DO NOT ATTACH!** But include entry tag and recipe with exhibit.

**Labels - For Non-Food Entries:** Please attach the entry tag to the upper right hand corner of the entry.

**GENERAL LABELING INFORMATION:** All additional information pieces (recipes, special items) must include the exhibitor's name and county.

Where an exhibitor brings a whole loaf of bread, pie or cake: Remember to bring a whole pie, whole cake and/or a whole loaf of bread.

**CRITERIA FOR JUDGING** - Exhibits will be judged according to score sheets available at the Extension Office or at <http://4h.unl.edu/state-fair>. Make sure to follow all entry instructions required for your exhibit. Incomplete exhibits will be lowered a ribbon placing. Commercially prepared mixes are allowed in the Tasty Tidbits Creative Mixes (Class 2) exhibit ONLY. Prepared baking mixes, biscuit mixes, or other pre-made mixes entered in other categories will be lowered a ribbon placing.

A good resource is the 4-H Foods Judging Guide available on-line at <http://4h.unl.edu/documents/2012%20Foods%20Judging%20Guide%20Edition.pdf>.

**ENTER FOOD PROJECTS** in disposable materials, i.e., paper plate and plastic self-sealing bag. The Fair Board is not responsible for lost bread boards, china or glassware. Plates and bags will not be provided.

Ingredients that the 4-H member cannot legally purchase, such as beer, whiskey, rum, etc. may not be used in any recipe or Foods exhibit. Exhibits that include alcohol in the recipe will be disqualified. This includes menu and recipe file exhibits.

**FOOD SAFETY** - Exhibits are on display for several days. Please limit exhibits to products which hold up well. Items that require refrigeration will not be accepted, judged or displayed. Food products must be unquestionably safe to eat when they are entered, whether tasted or not. Egg glazes on yeast products before baking are allowed. Glazes, frostings, and other sugar based toppings are also considered safe due to the high sugar content. Eggs incorporated into baked goods or crusts and cheeses mixed into bread dough are considered safe. All fruit must be cooked. Uncooked fruit is not allowed in any exhibit due to spoilage (i.e. fresh fruit tart). Cream cheese fillings and/or frostings are not allowed. Meat, dried meat, meat substitute pieces (bacon bits, pepperoni, etc.), or melted cheese toppings are not allowed in food exhibits. They may result in an unsafe food product by the time the

item is judged due to unpredictable heat/and or weather conditions and will be disqualified.

One item of each food exhibit (except the food preservation exhibits and the cake decorating exhibits) will be left on a plate with ribbon placing and information attached. The balance of the food exhibit will be put on a Bake Sale Table. The items will not be priced but a donation will be asked with the proceeds to go to the 4-H Council.

## **DIVISION 350 - GENERAL**

**SF-E350001 - FOOD SCIENCE AND EXPLORATION** - Open to any 4-H'er enrolled in a Foods and Nutrition project. Show the connection between food and science as it relates to food preparation, food safety, or food production. Scoresheet [SF152](#).

Exhibit may be a poster or foam core board (not to exceed 22" by 30"), computer based presentation printed off with notes pages, if needed, and displayed in binder, an exhibit display, a written report in portfolio or notebook. Consider neatness and creativity.

**SF-E350002 - FOODS AND NUTRITION - Poster, Scrapbook, or Photo Display** - Open to any 4-H'er enrolled in a Foods and Nutrition project, involving a nutrition or food preparation or career concept/lesson. This might contain pictures, captions, and/or reports to highlight the concept. Exhibit may be a poster or foam core board (not to exceed 22" by 30"), computer based presentation printed off with notes pages, if needed, and displayed in binder, an exhibit display, a written report in portfolio or notebook. Consider neatness and creativity. Scoresheet [SF122](#).

**SF-E350003 - PHYSICAL ACTIVITY AND HEALTH - Poster, Scrapbook, or Photo Display** - Open to any 4-H'er enrolled in a Foods and Nutrition project, involving a physical activity or career concept/ lesson. This might contain pictures, captions, and/or reports to highlight the concept. Exhibit may be a poster or foam core board (not to exceed 22" by 30"), computer based presentation printed off with notes pages, if needed, and displayed in binder, an exhibit display, a written report in portfolio or notebook. Consider neatness and creativity. Scoresheet [SF122](#).

## **DIVISION 400 - CAKE DECORATING**

### **DIVISION 400 - BEGINNING CAKE DECORATING**

County Exhibits Only

Beginning Cake Decorating - Using the Wyoming "*4-H Cake Decorating*" Manual (4 levels in the one manual)

**CF-E400900 - Set of 4 different buttercream techniques piped in color** - such as borders, leaves, writing, star, etc. learned in the beginning project piped on an 8" x 10" covered cardboard. Allow 1 inch space around outside for handling.

**CF-E400901 - Colorflow** - Exhibit a colorflow that contains no more than 2 colors on a 9 x 9 inch square covered cardboard leaving at least 1 inch border for handling.

**CF-E400902 - One layer cake** with techniques learned in the beginning project. The cake should be removed from the pan before it is decorated. The cake **MUST** be decorated with frosting only. No artificial decoration (plastic, candles, etc.) may be used. Cakes will be judged on neatness and techniques. Place cake on a foil covered cardboard. Allow cake board to extend 2 full inches larger than the cake. **DO NOT** cover cake.

**CF-E400903 - Plate of 4 Homemade Cupcakes and/or Plate of 4 Homemade Cookies** - all decorated identical using beginning skills and techniques. No purchased decorations allowed.

**CF-E400904 - Three page folder** containing descriptions of 3 cakes, cookies and/or cupcakes that you have decorated during the current project year. Include a sketch or picture. One description and sketch per page.

**CF-E400905 - Beginning Cake Decorating - Other** - Exhibit needs to relate to project area. You can add any additional information that you want the judge to know about your exhibit.

## **DIVISION 400 - ADVANCED CAKE DECORATING**

Advanced Cake Decorating - Using the Wyoming "*4-H Cake Decorating*" Manual (4 levels in the one manual)

**CF-E400906 - Set of 4 different buttercream techniques piped in color** - using advanced skills and techniques piped on an 8" x 10" covered cardboard. Allow 1 inch space around outside for handling.

**CF-E400907 - Plate of 4 Homemade Cupcakes and/or Plate of 4 Homemade Cookies** - all decorated identical using advanced skills and techniques. No purchased decorations allowed.

**CF-E400908 - Decorated cake using different skills and techniques** - using advanced skills and techniques.

**CF-E400909 - Decorated Cut-Up Cake** - using advanced skills and techniques.

**CF-E400910 - Cake or Exhibit Using Solid Sugar Molds** - using advanced skills and techniques.

**CF-E400911 - Cake Baked in Shaped Cake Pan** - using advanced skills and techniques.

**CF-E400912 - Decorated Stacked and/or Tiered Cake** - using advanced skills and techniques.

**CF-E415913 - Five page folder** - containing descriptions of 5 cakes, cupcakes and/or cookies that you have decorated during the current project year. Include a sketch or picture. One description and sketch per page.

**CF-E413914 - Confections** - homemade candies, caramels, etc. - 4 on a plate. Remember food safety - no raw egg or cream cheese recipes.

**CF-E400915 - Advanced Cake Decorating - Other** - Exhibit needs to relate to project area. You can add any additional information that you want the judge to know about your exhibit.

## 2017 WILTON FAIR AWARD GUIDELINES



Wilton Enterprises is pleased to help support the Holt and Boyd County fairs in the Decorated Cakes Divisions and the Cupcake Divisions.

Wilton will provide one "Best of Class" (or Grand Champion) award per category per fair, and one Runner-Up (or Reserve Grand Champion) award per category per fair. No exceptions.

2017 Best of Class Prize:

[Color Right Food Coloring System](#) and [Quick Tips Guide](#)

2017 Runner Up Prize:

[Quick Tips Guide](#)

Wilton will be offering the following categories for 2017:

### **Decorated Cake Division**

- 4H Class

### **Cupcake Division**

- 4H Class

## **DIVISION 401 - SIX EASY BITES**

**CF-E401900 - Quick Bread, Muffins, Biscuits** - (any recipe, non-yeast product) - Four muffins, four biscuits; or at least 3/4 of a standard loaf on a paper plate. A standard quick bread pan measures 8 x 5 inches.

**CF-E401901 - Baking History Interview** - Maximum of two pages, one sided, neatly handwritten or typed story of a baking history interview with an older person. Consider creativity and style of story. Mount on a 9" x 12" colored paper or poster board. Include a picture of the person interviewed on the first page of story for display purposes. May be laminated to preserve exhibit. Overall size of mounted exhibit should be no larger than 9 x 12 inches.

**CF-E401902 - Cookies** (any recipe) - Four on a paper plate.

**CF-E401903 - Six Easy Bites - Other** - Sample Ideas - brownies, bars, etc. Exhibit needs to relate to project area. You can add any additional information that you want the judge to know about your exhibit.

## **DIVISION 300 - YOUTH IN MOTION**

**CF-E300900 - YOUTH in Motion Poster, Scrapbook, or Photo Display** - about the 4-H'er or the 4-H'ers family or involved in a physical activity or concept/lesson involving this project. This might contain pictures, captions, and/or reports about the physical activity the individual or family did as a result of taking this project.

**CF-E300901 - Activity Bag** - A duffle bag or backpack that the 4-H'er packs so that they are always prepared to be active and make healthy food choices. May include proper workout attire, a healthy beverage or snack, a notebook or goal sheet, etc. Make sure all items are clean, clearly labeled and explain why they are included in the Activity Bag. DO NOT put valuable items (i.e. electronics) in Activity Bag, instead use a picture of the item or include in the listing of items.



**CF-E300902 - YOUTH in Motion Healthy Snack Recipe File** - Collection of 10 recipes from any source. Each recipe must accompany a complete snack menu in which the recipe is used, following the idea that a healthy snack includes foods from at least two different food groups. An additional 10 recipes may be added each year 4-H'er is in project, with year clearly marked on recipes. Consider creativity and neatness. Display in recipe file or in a binder. Be sure to include the number of servings or yield of each recipe.

**CF-E300903 - Healthy Lifestyle Interview** - Interview someone in your life that you admire that is physically active or has a healthy lifestyle. Why do they enjoy their exercise program or lifestyle choices? What are their goals? Why do you admire them? Maximum of two pages, one sided write up of an interview with someone who has an active exercise program or has a healthy lifestyle. Consider creativity and neatness. Mount on a 9" X 12" colored paper or poster board, or display in a binder. Include a picture of the person interviewed. (May be laminated to preserve exhibit.) Overall size of mounted exhibit should be no larger than 9 X 12 inches.

**CF-E300904 - Healthy Snack** - See ideas for non-perishable snacks on page 36. Four cookies, bars, muffins, etc., on a paper plate, or at least 1 cup of mix (examples might include: granola bars, homemade crackers or chips). Supporting information to include recipe and why this snack might be considered a healthy snack.

**CF-E300905 - Other** - Exhibit needs to relate to project area. You can add any additional information that you want the judge to know about your exhibit.

## **DIVISION 402 - FAST FOODS**

**SF-E402001 - Coffee Cake** - (any recipe or shape, non-yeast product) - At least 3/4 of baked product. May exhibit in a disposable pan. Include menu for a complete meal where this recipe is served. Scoresheet [SF129](#).

**SF-E402002 - Cost Comparison Exhibit** - Exhibit must include both the food product made from scratch and the comparable purchased product (for example, homemade cinnamon rolls compared to a pre-made cinnamon roll purchased at the store). Supporting information needs to include the cost of the food item made compared to the commercial product

and the recipe for the homemade food item. See pages 22 – 35 of Fast Foods Manual relating to the Grocery Store Tour and the Store Shopper Tip Sheet listed on page 31. Scoresheet [SF132](#).

**SF-E402003 - Fast Food Baked Product** - Exhibit must include a food product prepared using a non-traditional method (i.e. bread machine, cake baked in convection oven, baked item made in microwave, etc.) that saves time in food preparation. Entry must include supporting information that discusses alternative preparation method and how it compares with traditional method. Scoresheet [SF133](#).

**SF-E402005 - Fast Foods Recipe File** - Collection of 10 recipes from any source. Each recipe must accompany a complete menu in which the recipe is used. An additional 10 recipes may be added each year 4-H'er is in project, with year clearly marked on recipes. Display in recipe file or in a clear plastic binder. Be sure to include the number of servings or yield of each recipe. Scoresheet [SF251a](#).

**CF-E402900 - Fast Foods - Other** - Exhibit needs to relate to project area. You can add any additional information that you want the judge to know about your exhibit.

## **DIVISION 410 - TASTY TIDBITS**

**SF-E410001 - Healthy Baked Product** - Healthy Baked Product - any recipe, at least  $\frac{3}{4}$  of baked product or 4 muffins or cookies on a paper plate. May be baked in a disposable pan. Must be made with less sugar, fat or salt; modified to use a sugar or fat substitute; changed to include a whole grain; or be altered for specific allergies/food intolerances. Include original recipe and altered recipe. **Write what you learned about products made from an altered recipe in supporting information.** Scoresheet [SF123](#).

**SF-E410002 - Creative Mixes** - (any recipe, at least  $\frac{3}{4}$  of baked product or 4 muffins or cookies on a paper plate. Exhibit may be baked in a disposable pan.) Baked item made from a mix (commercial or homemade mixes acceptable). Food product must have been modified to make a new or different baked item. (Examples include - poppy seed quick bread from a cake mix, cake mix cookies, sweet rolls made from readymade bread dough, monkey breads from biscuit dough, streusel coffee cake from a cake mix,

etc.) **Write what you learned about making this product using a mix instead of a homemade recipe or recipe "from scratch". Does it make it better or easier to use a convenience product or mix? Why or why not?** Scoresheet [SF142](#).

**SF-E410003 - Biscuits** - Four biscuits on a small paper plate. May be rolled, dropped, or cut into shape. Any recipe. Recipe must be a non-yeast product baked from scratch. Scoresheet [SF136](#).

**SF-E410004 - Unique Baked Product** - (any recipe, at least  $\frac{3}{4}$  of baked product or 4 muffins or cookies on a paper plate. May be baked in a disposable pan.) Recipe must contain a surprise ingredient and **MUST** not use a mix (examples include - cantaloupe quick bread, pork and bean bread, etc.) **Write what you learned about making this unique item with an unusual ingredient. What was the anticipated outcome? Would you make it again?** Scoresheet [SF2012-001](#).

**SF-E410005 - Foam Cake** - original recipe (no mixes) of at least  $\frac{3}{4}$  of the cake. Foam cakes are cakes that have a high ratio of eggs to flour and fall into three categories: angel food cakes or meringues; sponge or jelly roll cakes; and chiffon cakes. Scoresheet [SF134](#).

**CF-E410900 - Tasty Tidbits - Other** - Exhibit needs to relate to project area. You can add any additional information that you want the judge to know about your exhibit.

## **DIVISION 411 - YOU'RE THE CHEF**

Any bread item prepared or baked using a bread machine should be entered under the Fast Foods - Food Technology exhibit. All exhibits made in the You're the Chef and Foodworks project areas must have been prepared without the assistance of a bread machine for mixing, raising, or baking of the food item.

**SF-E411001 - Loaf Quick Bread** - (any recipe). At least  $\frac{3}{4}$  of a standard loaf displayed on a paper plate. A standard quick bread loaf measures  $8\frac{1}{2}$ " x  $4\frac{1}{2}$ " or 9" x 5". If mini-loaf pans are used for exhibit, two loaves must be presented for judging. Scoresheet [SF128](#).

**SF-E411002 - White Bread** - (any yeast recipe). At least  $\frac{3}{4}$  of a standard loaf displayed on a paper plate. Scoresheet [SF138](#).

**SF-E411003 - Whole Wheat or Mixed Grain Bread** - (any yeast recipe). At least  $\frac{3}{4}$  of a standard loaf displayed on a paper plate. Scoresheet [SF138](#).

**SF-E411004 - Specialty Rolls** - (any yeast recipe). 4 rolls on a paper plate. May be sweet rolls, English muffins, kolaches, bagels, or any other similar recipe that makes individual portions. Scoresheet [SF138](#).

**SF-E411005 - Dinner Rolls** - (any yeast recipe). 4 rolls on a paper plate. May be clover leaf, crescent, knot, bun, bread sticks, or any other type of dinner roll. Scoresheet [SF138](#).

**CF-E411900 - You're the Chef - Other** - Exhibit needs to relate to project area. You can add any additional information that you want the judge to know about your exhibit.

## **DIVISION 413 - FOODWORKS**

Any bread item prepared or baked using a bread machine should be entered under the Fast Foods - Food Technology exhibit. All exhibits made in the You're the Chef and Foodworks project areas must have been prepared without the assistance of a bread machine for mixing, raising, or baking of the food item.

**SF-E413001 - Double Crust Fruit Pie** - Made with homemade fruit filling. No egg pastries or cream fillings. No commercial canned fillings. May be a double crust, crumb or lattice topping. Using an 8- or 9-inch disposable pie pan is recommended. Scoresheet [SF144](#).

**SF-E413002 - Family Food Traditions** - (any recipe, at least  $\frac{3}{4}$  of baked product or 4 muffins or cookies on a paper plate. May be baked in a disposable pan.) Any baked item associated with family tradition and heritage. Entry must include (A) recipe, (B) tradition or heritage associated with preparing, serving the food, (C) where or who the traditional recipe came from. Scoresheet [SF2012-002](#).

**SF-E413003 - Cultural Foods Exhibit** - (any recipe, at least  $\frac{3}{4}$  of baked product or 4 muffins or cookies on a paper plate. May be baked in a disposable pan.) The name of the country, culture or region should be included as part of the supporting information with the recipe, as well as some background information about the country or culture the food item is representing. Scoresheet [SF146](#).

**SF-E413005 - Specialty Bread** -(any recipe made with yeast). Tea rings, braids, or any other full-sized specialty bread products. Must exhibit at least  $\frac{3}{4}$  of a full sized baked product. May be baked in a disposable pan. Scoresheet [SF141](#).

**SF-E413006 - Specialty Pastry** - (any recipe, at least  $\frac{3}{4}$  of baked product or 4 muffins or cookies on a paper plate. May be baked in a disposable pan.) Baked items such as pie tarts, puff pastry, phyllo doughs, scones, biscotti, choux, croissants, danish, strudels. Phyllo dough may be premade or from scratch. Pastries made with cream or egg based fillings will be disqualified. Scoresheet [SF143](#).

**CF-E413900 - Foodworks - Other** - Exhibit needs to relate to project area. Project examples include: report about catering business, local restaurant, health care food service, food scientist, Registered Dietitian, or any other food or nutrition related industry, etc. You can add any additional information that you want the judge to know about your exhibit.

## **DIVISION 407 - FOOD PRESERVATION**

### **GENERAL INFORMATION:**

#### **1. PROCESSING METHODS - Current USDA processing methods and altitude adjustments must be followed for all food preservation.**

Jam, preserves and marmalades, fruit, tomatoes and pickled products must be processed in a boiling water bath. (Tomatoes may be processed in a pressure canner.) All non-acid vegetables and meats must be processed in a pressure canner.

Paraffin should not be used to seal canned goods. Open kettle canning (putting hot food in a jar, putting a lid on in and giving it no further processing) is not acceptable for any "canned" product.

Soup mixes and other foods with thickeners (like flour or starch), cream or milk, pasta/noodles, or rice are not permitted.

#### **Spoiled or unsealed container disqualifies entry.**

**2. UNIFORMITY** - Jars and type of lid should be the same size, all small or all large, not necessarily the same brand. Half pint jars may be used for jellies and preserves. The jars are not to be decorated in any way. Canning jars must be used - others will be disqualified. No one fourth pint jars allowed.

Leave jar rings on for fair display, it helps protect the seal. **No zinc lids.** Improperly canned or potentially hazardous food items will be disqualified.

**3. CURRENT PROJECT** - All canning must be the result of this year's 4-H project, since September 1, of the previous calendar year.

**4. CRITERIA FOR JUDGING** - Exhibits will be judged according to score sheets available at the Extension Office or at <http://4h.unl.edu/nebraska-state-fair>. Incomplete exhibits will be lowered a ribbon class. Canned food items not processed according to altitude in the county will be lowered one class ribbon. Check with the Extension Office for our county's altitude and how that affects food processing times and pounds of pressure.

**5. DISPLAY** - Enter food projects in disposable materials, i.e., paper plate or plastic self-sealing bag. The Fair Board is not responsible for lost bread boards, china or glassware.

**6. RECIPE /LABELING** - Recipe must be included, may be handwritten, photocopied or typed. Commercially prepared mixes are not allowed. See <http://food.unl.edu/web/preservation/home> for current USDA guidelines, how to find your Nebraska altitude, and proper procedures for food preservation. Jars should be labeled with name of 4-H'er, county, name of product and date of processing. Write plainly on a label and paste or tape securely on jar bottom. In addition:

**All canned foods must include the following supporting information on the label of the item:**

1. Method of preservation (pressure canner or water bath canner)
2. Type of pack (raw pack or hot pack)
3. Altitude (and altitude adjustment if needed)
4. Processing time
5. Number of pounds of pressure (if pressure canner used)
6. Recipe and source of recipe (If a publication, include name and date) **RECIPE CAN COME FROM ANY SOURCE BUT CURRENT USDA GUIDELINES FOR FOOD PRESERVATION METHODS MUST BE FOLLOWED.** See <http://food.unl.edu/web/preservation/home> for current USDA guidelines.

**All dried foods must include the following supporting information:**

1. Recipe and recipe source
2. Method of pretreatment
3. Drying method and drying time.

Write plainly on label and attach securely to exhibit. Securely attach official entry card to exhibit. Multiple dried food exhibits should be secured by rubber band or "twisty" to keep exhibit containing the 3 self-sealing bags together.



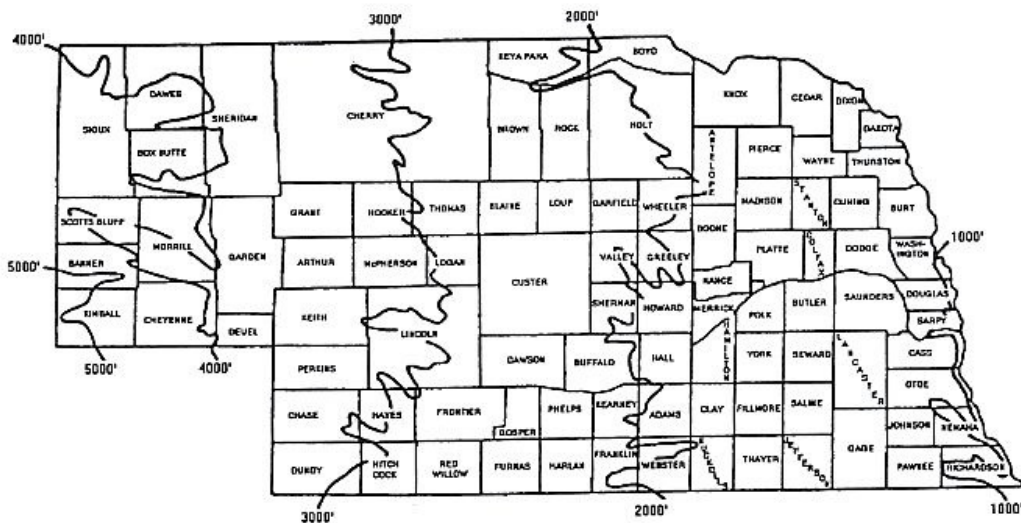
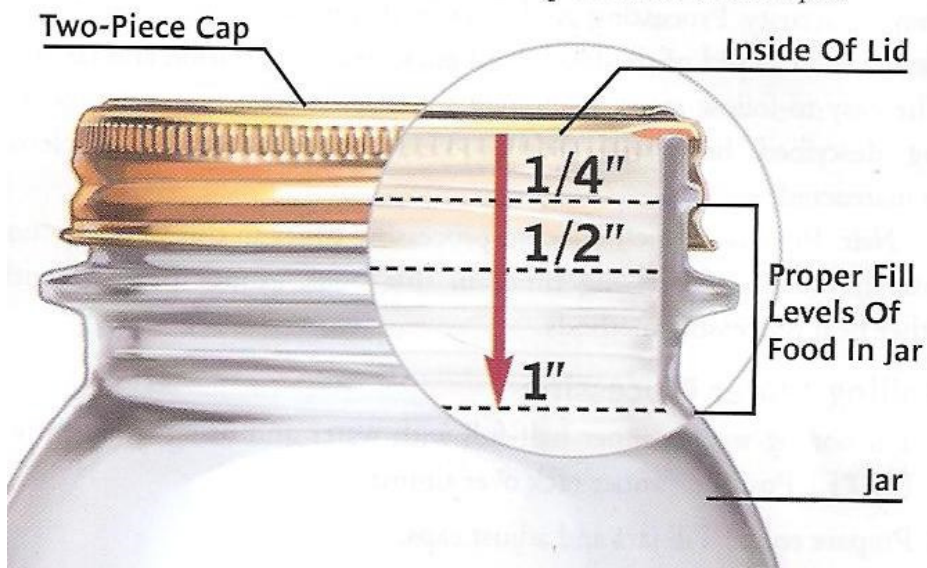

Figure 1. Altitude ranges in Nebraska.

Map was prepared by Les Howard, cartographer, UNL School of Natural Resources

figure 6 | Measuring Headspace (Diagram is not to scale)

Measure Headspace From The Inside Of The Lid To The Top Of The Food Or Liquid.





## **Information on Fruit Spreads**

What is the difference between jam and jelly? Marmalade and preserves? All of these fruit spreads have four basic ingredients: fruit, sugar, acid and pectin. The method of preparing and cooking the ingredients is what makes the difference.

Jelly uses strained juice from fresh fruit. The end product has a clear, shimmering appearance. It holds its shape when removed from the jar yet spreads easily.

Jam requires crushed or chopped fruit. Jam is cooked until it rounds up in a spoon. Jam should be slightly firm. It will not retain its shape. Jam is less firm than jelly. Thickness results from cooking the excess liquid out. Prepare jam in small batches and cook rapidly.

Preserves contain whole fruit or large pieces of fruit suspended in thick syrup. The fruit retains its shape. Use a pan with a wide opening and work in small batches.

Marmalades are jellies with pieces of fruit, pulp and peel suspended throughout. When preparing the fruit, leave some of the white pith that is next to the peel. The white pith is high in pectin, which makes the jelly "jel". Marmalades are cooked rapidly until close to the jelling point.

Conserves are jam-like mixtures of two fruits. Prepare them in small batches and cook rapidly after the sugar has dissolved.

Fruit batters are smooth, thick spreads created by cooking fruit pulp and sugar slowly to the desired consistency. Spices are often added to complement fruit flavors.

Regardless of the type of fruit spread you prepare, use a test recipe and do not adjust the proportions of ingredients. You may end up with a unique product. And remember, according to the USDA, fruit spreads must be processed in a boiling water bath. The use of paraffin is NOT recommended.

**SF-E407001 - Dried Fruits** - Exhibit 3 different examples of dried fruit. Place each dried fruit food (6-10 pieces of fruit, minimum 1/4 cup) in separate self-sealing bags. Use a rubber band or "twisty" to keep exhibit together. Scoresheet [SF147](#).

**SF-E407002 - Fruit Leather** - Exhibit 3 different examples of 3 different fruit leathers. Place a 3-4" sample of each fruit together in separate self-sealing bags. Use a rubber band or "twisty" to keep exhibit together. Scoresheet [SF147](#).

**SF-E407010 - Dried Vegetables** - Exhibit three different examples of dried vegetables. Place each food (1/4 cup of each vegetable) in a self-sealing bag. Use a "twisty" to keep exhibit together. Scoresheet [SF149](#).

**SF-E407011 - Dried Herbs** - Exhibit three different examples of dried herbs. Place each food (1/4 cup of each herb) in a separate self-sealing bag. Use a "twisty" to keep exhibit together. Scoresheet [SF149](#).

**SF-E407012 - 1 Jar Fruit Exhibit** - One jar of a canned fruit. Entry must be processed in the boiling water bath according to current USDA recommendations. Scoresheet [SF150](#).

**SF-E407013 - 3 Jar Exhibit** - Three jars of different canned fruits. May be three different techniques for same type of product, ex. Applesauce, canned apples, apple pie filling, etc. Entry must be processed in the boiling water bath according to current USDA recommendations. Scoresheet [SF150](#).

**SF-E407014 - 1 Jar Tomato Exhibit** - One jar of a canned tomato product. Entry must be processed in a boiling water bath or pressure canner according to current USDA recommendations. Scoresheet [SF150](#).

**SF-E407015 - 3 Jar Tomato Exhibit** - Exhibit 3 jars of different canned tomato products (salsa, sauces without meats, juice, stewed, etc.) Entry must be processed in the boiling water bath or pressure canner according to current USDA recommendations. Scoresheet [SF150](#).

**SF-E407020 - 1 Jar Vegetable or Meat Exhibit** - One Jar of a canned vegetable or meat. Include only vegetables and meat canned in a pressure canner. Scoresheet [SF150](#).

**SF-E407021 - 3 Jar Vegetable Exhibit** - Three jars of different kinds of canned vegetables. Include only vegetables canned in a pressure canner according to current USDA recommendations. Scoresheet [SF150](#).

**SF-E407022 - Quick Dinner** - Exhibit a minimum of three jars to a maximum of 5 jars (all the same size) plus menu. Meal should include three canned foods that can be prepared within an hour. List complete menu on 3 x 5" file card and attach to one of the jars. Entry must be processed according to current USDA recommendations. Scoresheet [SF151](#).

**SF-E407030 - 1 Jar Pickled/Fermented Exhibit** - One jar of a pickled and/or fermented product. Entry must be processed in the boiling water bath according to current USDA recommendations. Scoresheet [SF150](#).

**SF-E407031 - 3 Jar Pickled/Fermented Exhibit** - Three jars of different types of pickles and/or fermented products. Entry must be processed in the boiling water bath according to current USDA recommendations. Scoresheet [SF150](#).

**SF-E407040 - 1 Jar Jelled Fruit Exhibit** - One jar of a jam, jelly or marmalade. Entry must be processed in the boiling water bath according to current USDA recommendations. Scoresheet [SF153](#).

**SF-E407041 - 3 Jar Jelled Fruit Exhibit** - Three different kinds of jellied fruit products. Entry may be made up of either pints or half pints (but all jars must be the same size). Entry must be processed in the boiling water bath according to current USDA recommendations. Scoresheet [SF153](#).

**CF-E407907 - Food Preservation - Other** - Exhibit needs to relate to project area. Suggested exhibits: canned meats, poultry, reduced sugar, without added pectin, educational, etc. (Include only meat or poultry that has been canned in a pressure canner.) You can add any additional information that you want the judge to know about your exhibit.

## **DEPARTMENT E - SAFETY**

### **DIVISION 440 - CITIZEN SAFETY CLASSES**

All static exhibits must have received a purple ribbon at the county fair to advance to the State Fair. Premier 4-H Science Award is available in this area. Please see Department H for more details.

**SF-E440001 - First Aid Kit** - A first aid kit is a good way to organize supplies in an emergency. The kit should be assembled in a container appropriate for the kit's intended use. A description of where the kit will be stored and examples of specific emergencies for that situation should be included in the exhibit. The kit should include a written inventory and purpose statement for included items. Items should cover the following areas: airway and breathing, bleeding control, burn treatment, infectious disease protection, fracture care and miscellaneous supplies. Use Citizen Safety manual, 4-H 425, pages 6 & 7 and score sheet SF110 for guidance. a. Kits containing any of the following will be automatically disqualified: 1. Prescription medications. (If the kit's purpose is to provide medication for someone with special needs, explain in the written description and inventory, but remove the medication.) 2. Materials with expiration dates on or before the judging date. (This includes sterile items, non-prescription medications, ointments, salves, etc. Articles dated month and year only are considered expired on the last day of that month.) 3. Any controlled substance. Scoresheet [SF110](#).

**SF-E440002 - Disaster Kit (Emergency Preparedness)** - Disaster kits must contain the materials to prepare a person or family for emergency conditions caused by a natural or man-made incident. Selection of materials is left to the exhibitor. Family or group kits must have enough material or items for each person. A description of the kit's purpose, the number of people supported and a list of contents is required. Youth are encouraged to test their kit by challenging their family to try to survive using only the included materials for the designated time. If tested, share that experience in kit documentation. Please include an explanation of drinking water needs for your disaster kit. Do not bring actual water to the fair in the kit. Scoresheet [SF111](#).

**SF-E440003 - Safety Scrapbook** - The scrapbook must contain 15 news articles from print and/or internet sources about various incident types. Mount each clipping on a separate page accompanied by a description of events leading to the incident and any measures that might have prevented it. The Scrapbook should be bound in a standard size hardcover binder or notebook for 8 ½" X 11" size paper. Correct sentence structure, readability and thorough explanations are an important part of judging. Scoresheet [SF292](#).

**SF-E440004 - Safety Experiences** - The exhibit should share a learning experience the youth had related to safety. Examples could be participating in a first aid or first responder training, a farm safety day camp, babysitting workshop or similar event; scientific experiment related to safety; or the youth's response to an emergency situation. The exhibit should include a detailed description of the experience, the youth's role, some evidence of the youth's leadership in the situation and a summary of the learning that took place. Exhibits may be presented in a poster with supplemental Rev. 12/19/2014 documentation, a notebook including up to ten pages of narrative and pictures, or a multimedia presentation on a CD lasting up to five minutes. Scoresheet [SF190](#).

**SF-E440005 - Career in Safety** - The exhibit should identify a specific career area in the safety field and include education and certification requirements for available positions, salary information, demand for the field and a summary of the youth's interest in the field. Examples of careers include firefighters, paramedics, emergency management personnel, some military assignments, law enforcement officers, emergency room medical personnel, fire investigator and more. It is recommended youth interview a professional in the field in their research. Additional research sources might include books, articles, career web sites, job-related government web sites or interviews with career placement or guidance counselors. Exhibits may be presented in a poster with supplemental documentation, a notebook including up to ten pages of narrative and pictures, or a multimedia presentation on a CD lasting up to five minutes. Scoresheet [SF191](#).

**CF-E440900 - Citizen Safety - Other** - Exhibit needs to relate to project area. You can add any additional information that you want the judge to know about your exhibit.

## DIVISION 450 - FIRE SAFETY

**SF-E450001 - Fire Safety Poster** - This is a home floor plan drawn to scale showing primary and secondary escape routes and where fire extinguishers and smoke detectors are located. Draw every room, including all doors and windows. Use **black** or **blue** arrows showing **primary** escape routes from each room. Use **red** arrows showing **secondary** routes to use if the primary routes are blocked. Primary and secondary escape routes must lead outside to an assembly location. Documentation should include evidence the escape plan has been practiced at least four times. Posters must be constructed of commercial poster board at least 11" x 14" but not larger than 22" x 28". Scoresheet [SF269](#).

**SF-E450002 - Fire Safety Scrapbook** - The scrapbook must contain 10 news articles from print and/or internet sources about fires to residential or commercial properties or landscapes. Mount each clipping on a separate page accompanied by a description of events leading to the incident and any measures that might have prevented it. The Scrapbook should be bound in a standard size hardcover binder or notebook for 8 ½" X 11" size paper. Correct sentence structure, readability and thorough explanations are an important part of judging. Scoresheet [SF270](#).

**SF-E450003 - Fire Prevention Poster** - Posters should promote a fire prevention message and be appropriate to display during National Fire Prevention Week or to promote fire safety at specific times of the year (Christmas, Halloween, 4th of July, etc.). Originality, clarity and artistic impression will all be judged. Do not include live fireworks, matches or other flammable/explosive/hazardous materials. Any entry containing this material will be disqualified. Posters must be constructed of commercial poster board at least 11" x 14" but not larger than 22" x 28". Scoresheet [SF1268](#).

**CF-E450900 - Fire Safety - Other** - Examples include: posters, scrapbooks, etc. about fire safety; safety in the home; fire safety promotion, etc. Exhibit needs to relate to project area. You can add any additional information that you want the judge to know about your exhibit.

## DIVISION 460 - WEATHER SAFETY

**CF-E460900 - Weather Safety - Other** - Examples include; Rain Gauge; Barometer; Monthly Weather Chart; Weather Vane; Scrapbook or Notebooks on Weather Safety. Exhibit needs to relate to project area. You can add any additional information that you want the judge to know about your exhibit.

## **DEPARTMENT E – HEALTH**

### **DIVISION 200 - HEALTH CLASSES**

**CF-E470900 - Health** - Poster, notebook, or scrapbook. Include, using any means you wish, information about any topic. Examples: nutrition, physical fitness, sports injuries, physical development, weight control or eating disorders, dating, peer pressure, choosing not to smoke and/or use alcohol, skin safety, cancer, abuse, disabilities, friendships, families, decision making, problem solving, understanding advertising, behavior, TV violence, self-worth, beliefs, cultural differences, stress, study habits, time management, goal setting, careers, seat belts, home fire safety, first aid, etc.

**CF-E470901 - Healthy Lifetime Sports** - Exhibit may be a poster or foam core board or wood (not to exceed 22" x 30"), a notebook or a small display of an educational nature. Examples include (but not limited to): **Bicycle** - maintenance record of your bicycle; traffic law; road rules; safety (helmet selection, reflective clothing, etc.); appropriate handling skills; bike parts; journaling; your goals and learnings for the year and your plans for next year. **Bicycle Demonstration Display** - Exhibit may include 1) parts or system of a bicycle, 2) worn or broken parts or 3) a step by step procedure of how some repair or service job is performed. A limited number of photographs are acceptable. Actual parts or cut-away of parts are recommended. **Golf, Tennis or Bowling** - equipment and supplies needed, diagram of a skill or term; your goals and learnings for the year; scoring; terms; safety; record of practice and scores of games played to show progress.